

NOTES:

- PATTERN: SOLID HORIZONTAL LINE 0.125MM WIDTH WITH VERTICAL TICKS ON 1MM SPACING CENTERED ON TOP SURFACE OF BLANK, RIGHT READING LOOKING AT
- TOLERANCES:  
 LINE WIDTH: 0.125MM ±0.005MM  
 POSITIONAL ACCURACY: ±0.003MM UP TO 300MM  
                           ±0.005MM UP TO 640MM  
                           ±0.007MM UP TO 1000MM
- COATING: REFLECTIVE CHROMIUM FIRST SURFACE. OPTICAL DENSITY > 3.0.  
 COATING DESIGNED TO PROVIDE REFLECTION 50% ±5% @ 550 NM
- MATERIAL:  
 SODA LIME GLASS: 6.35MM NOMINAL THICKNESS, PHOTO QUALITY SELECT SODA LIME FLOAT GLASS.  
 LOW CTE GLASS: 4.8MM NOMINAL THICKNESS BOROFLOAT CTE 3.25\*10<sup>-6</sup> K-1
- FLATNESS: TOP SURFACE OF SODA LIME GLASS TO BE ±0.050MM
- EDGES: BREAK SHARP EDGES. NO VISIBLE EDGE CHIPS > 0.25 MM DIAMETER
- SURFACE QUALITY: SCRATCH: DIG OF 40:20 OVER PATTERN AREA
- GLASS SIZE: BLANK IS 50.8MM WIDE ±1.5MM. GLASS EDGES ARE SAFETY BEVELED.

DATE	SYM	REVISION RECORD	AUTH	DR	CK
5/05	A	UPDATED TOLERANCES	RCC		DSM
10/19	D	CHANGE LOW CTE GLASS TO BOROFLOAT	SS		

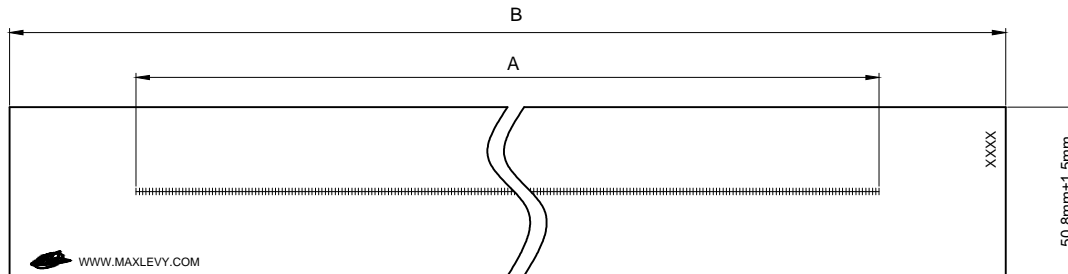
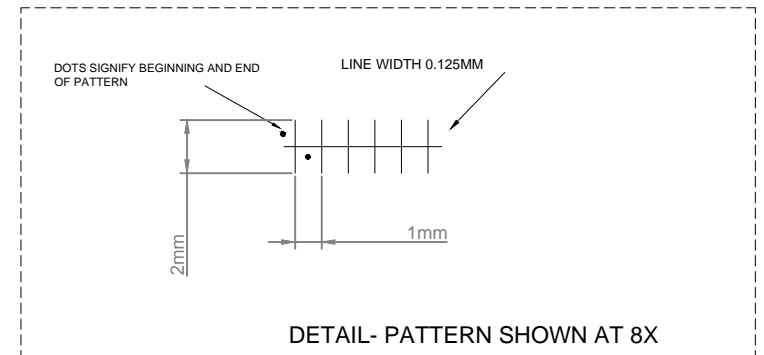

		SODA LIME GLASS		LOW CTE GLASS	
A	B	DASH NO	STOCK NO	DASH NO	STOCK NO
300MM	369MM	-001	EA030	-013	EA042
640MM	699MM	-002	EA031	-014	EA043
1000MM	1080MM	-003	EA032	-015	EA044

SHEET 1 OF 4					
MAX LEVY AUTOGRAPH					
TOLERANCES (EXCEPT AS NOTED)	MATERIAL		SCALE	DRAWN BY	
DECIMAL .XXX= +/--.005 .XX= +/--.015 .X= +/--.030	SEE NOTES		NONE	KJV	
FRACTIONAL +/--.030	TITLE VISION SYSTEM PRECISION SCALE				
ANGULAR +/-0.5Deg.	DATE	DRAWING NUMBER			
	6/21/04	300MLA0108-0XX			