

MAX LEVY AUTOGRAPH, INC. PROPRIETARY

THIS DRAWING CONTAINS CONFIDENTIAL PROPRIETARY INFORMATION THAT IS MAX LEVY AUTOGRAPH, INC. PROPERTY. DO NOT DISCLOSE NOR DUPLICATE FOR OTHERS EXCEPT AS AUTHORIZED BY MAX LEVY AUTOGRAPH, INC.

| DATE | SYM | REVISION RECORD | AUTH | DR | CK |
|------|-----|-----------------|------|----|----|
| | | | | | |
| | | | | | |
| | | | | | |
| | | | | | |
| | | | | | |
| | | | | | |

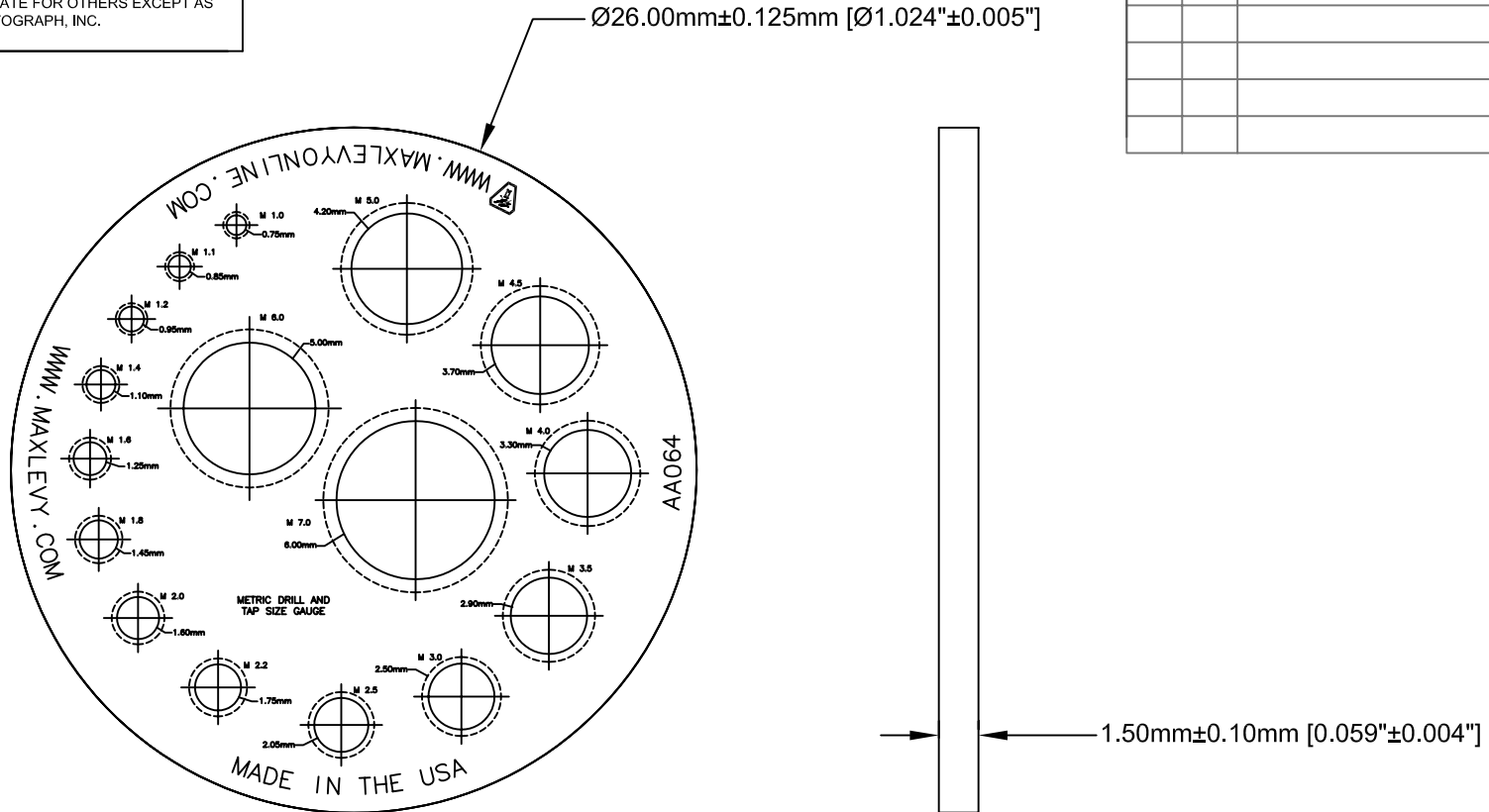

NOTES:

1. BEVEL: REMOVE SHARP EDGES.
2. SURFACE FLATNESS: 3-4 WAVES
3. SURFACE QUALITY: SCRATCH:DIG 20:10 OVER ACTIVE AREA
4. PARALLELISM: < 30 ARCSEC
5. PATTERN OVERALL DIMENSIONAL ACCURACY: 0.00004" (0.001MM)
6. PATTERN TO BE CENTERED ON SUBSTRATE ±0.004" (±0.10MM)
7. PATTERN LINEWIDTH IS 0.001" ±0.0001" (0.0254MM ±0.0025MM)
8. PATTERN ORIENTATION: RIGHT READING LOOKING THROUGH.
9. COATING: LOW REFLECTION CHROMIUM FIRST SURFACE. CHROMIUM ADHESION LAYER WITH A TOP LAYER OF CHROMIUM OXIDE, OPTICAL DENSITY > 3.0. COATING DESIGNED TO PROVIDE REFLECTION < 5% @ 550 NM
10. PATTERN:
16 SETS OF CIRCLES. DRILL AND TAP SIZE MEASUREMENTS TO INCLUDE: M1.0 TO M7.0. OUTER DIAMETER OF TAP GAUGE INDICATES NOMINAL THREAD O.D.
11. PACKAGING: BAG AND TAG PER 700MLA0060-001
12. PATTERN DIAMETER: 22.070MM

| | | | |
|---|-------------------------------|----------------------------------|-----------------|
| MLO PART NUMBER: AA064 | | ONLINE CATALOG RD2055 | |
| TOLERANCES (EXCEPT AS NOTED) | MAX LEVY AUTOGRAPH | | |
| DECIMAL .XXX= +/-,005 .XX= +/-,015 .X= +/-,030 | MATERIAL SODA LIME GLASS | SCALE NONE | DRAWN BY TEN |
| FRACTIONAL +/-,030 | TITLE THREAD GAUGE, METRIC | | |
| ANGULAR +/-0.5Deg. | DATE 01/09/01 | DRAWING NUMBER 300MLA0069-022 | |